

Aula Aberta: Faculdade de Engenharia da Universidade da Beira Interior



Apresentação:
Miguel Sousa Pinto
arquiteto

19 Abril 2016

3A COMPOSITES



ALUCOBOND®

Setores da 3A COMPOSITES:

- CORE MATERIAL
- ARCHITECTURE & DESIGN
- DISPLAY & GRAPHIC ARTS
- TRANSPORT & INDUSTRY

o que é o

ALUCOBOND®

como é utilizado

O que é o ALUCOBOND® ?

- O ALUCOBOND® é um painel compósito de alumínio composto por duas lâminas de alumínio, liga EN AW 5005A , e por um núcleo central que confere ao conjunto uma excelente resistência mecânica.

O que é o ALUCOBOND® ?

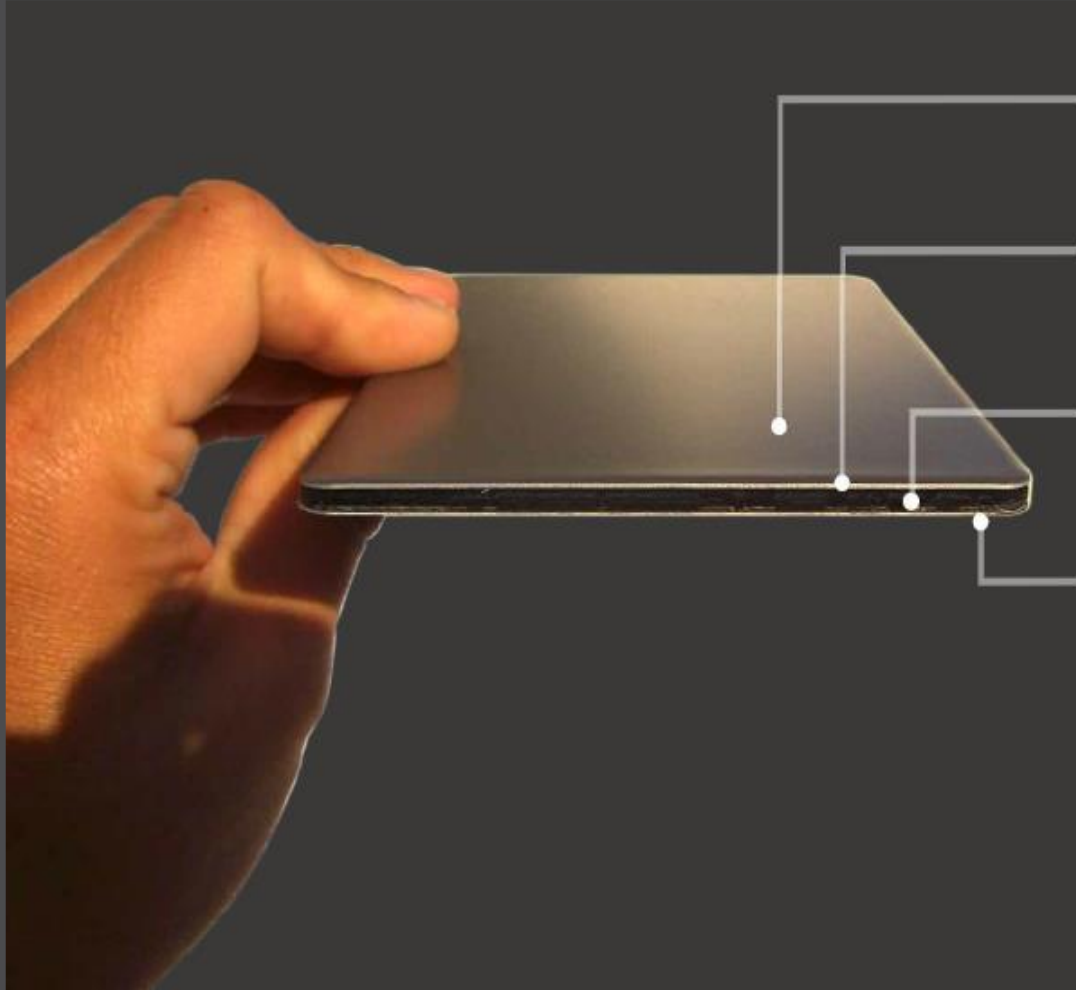

lacado **PVDF**

dupla capa ou tri capa

Chapa de **ALUMÍNIO 0,5mm**

liga de alumínio AW-EN 5005 A

NÚCLEO - PLUS/ A2

Chapa de **ALUMÍNIO 0,5mm**

liga de alumínio AW-EN 5005 A

espessuras

3mm, **4mm** e 6mm

Tipos de ALUCOBOND® ... só varia o núcleo

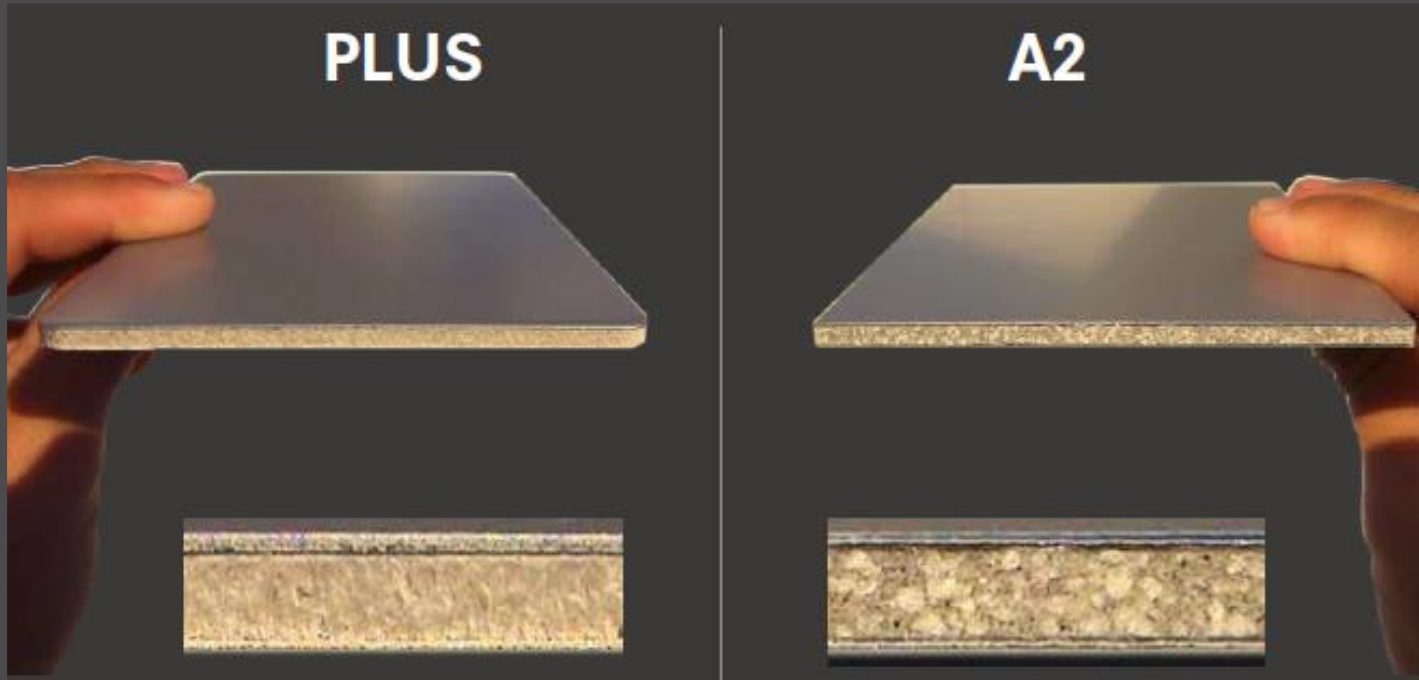

núcleo **mineral**
classe B, s1-d0

núcleo **mineral**
classe A2, s1-d0

Como se aplica o ALUCOBOND® ?

como **FACHADA VENTILADA**

1 – Suporte de fixação

2 – Isolamento térmico

3 – Estrutura portadora e distanciadores

4 – Câmara de ar

5 - ALUCOBOND

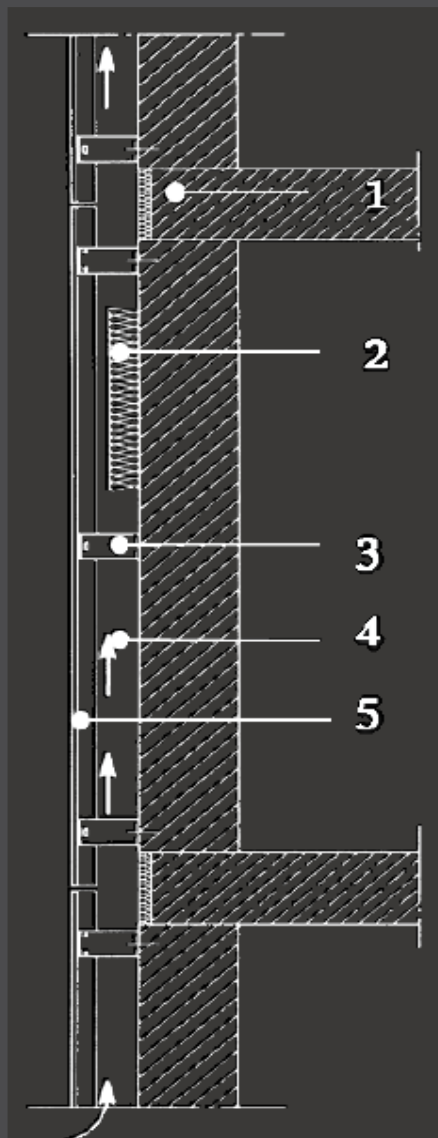

Como se fabrica o

ALUCOBOND®

Produção do ALUCOBOND®



Lingotes de alumínio → Bobina de alumínio → Lacagem e laminação das bobinas de alumínio

Lacado Contínuo de acordo com as regras da ECCA

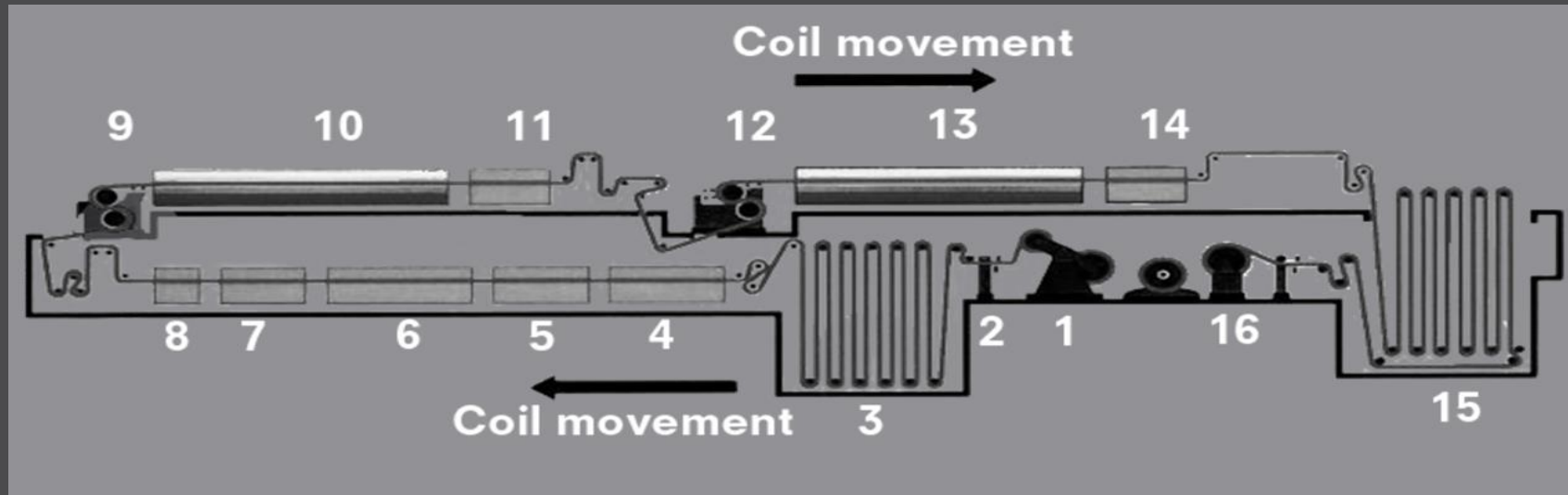

1 - Bobina de saída

2 - Guilhotina / unidade de emenda

3 - Acumulador de entrada

4/5 - Pré-tratamento 1ª fase

6/7/8 - Pré-tratamento 2ª fase

9 - Primeira lacagem

10 - Forno - cura da lacagem

11 - Arrefecimento

12 - Segunda lacagem

13 - Forno - cura da lacagem

11 - Arrefecimento

12 - Acumulador de saída

13 - Bobina de saída lacada

Laminação das bobinas de Alumínio origina o ALUCOBOND®

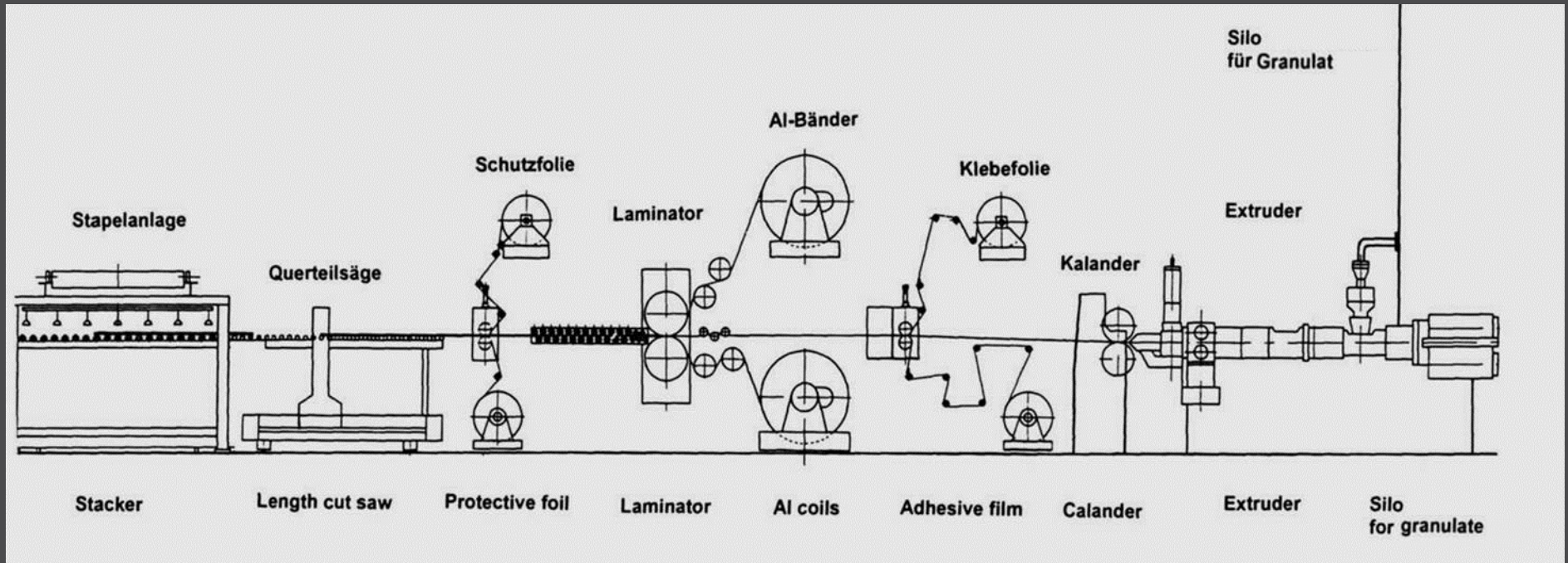

Vantagens do

ALUCOBOND®

Vantagens do ALUCOBOND®

Comparação de espessura e peso com mesma rigidez à flexão

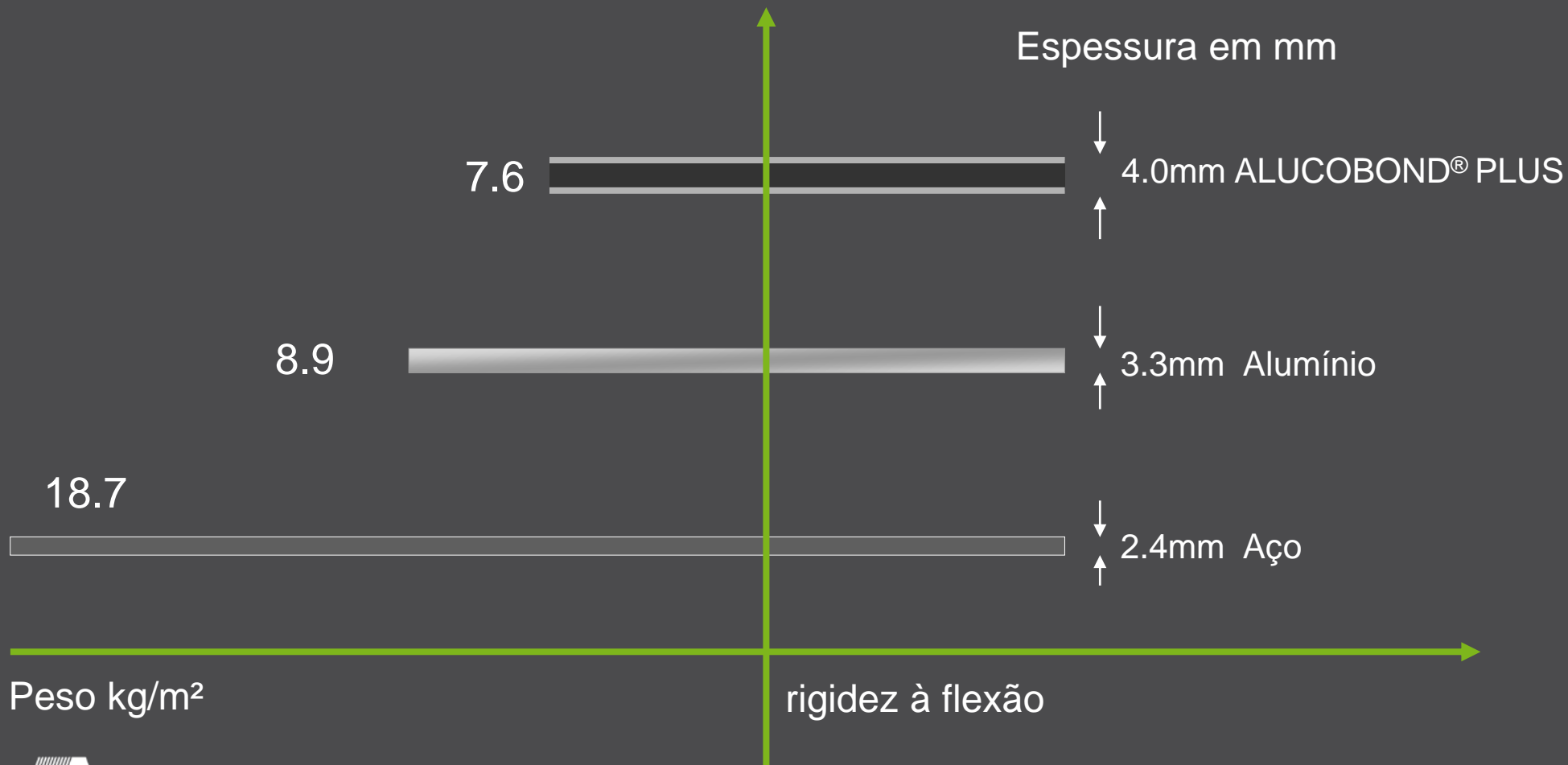

Vantagens do ALUCOBOND®



- Liga de alumínio: Peraluman-100, EN AW 5005A (AlMg1)
- Alta resistência à corrosão
- Boa capacidade de modelação

Vantagens do ALUCOBOND®

Reciclagem Total:



- O ALUCOBOND® é 100% livre de produtos contaminantes
- Lacas sem chumbo
- O alumínio pode ser reciclado na totalidade
- Materiais do núcleo: 100% recicláveis e a energia para a realizar é muito baixa

Vantagens do ALUCOBOND®



ECOLOGICAMENTE
SEGURO



RECICLAGEM



PROTEÇÃO CONTRA A
HUMIDADE



POUPANÇA EM CUSTO DE
AQUECIMENTO

Gama do produto

ALUCOBOND®

Gama do ALUCOBOND®

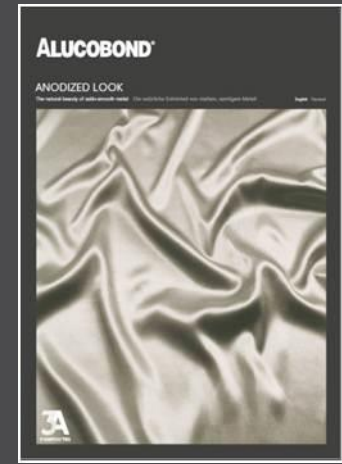

- ALUCOBOND® Standard colours
- ALUCOBOND® spectra
- ALUCOBOND® Ligno
- ALUCOBOND® naturAL
- ALUCOBOND® Anodized Look
- ALUCOBOND® Terra
- ALUCOBOND® Urban



Gama do produto ALUCOBOND® / ALUCOBOND® plus

Espessuras: 3 / 4 mm (6 mm por pedido)

Largura [mm]	1 000	1 250	1 500	1 575	1 750
Comprimento [mm]	2 000 – 6 800 mm				
Solid Colours	●	●	●	●	○
Metallic Colours	●	●	●	●	○
Spectra & sparkling	●	●	●	○	--
naturAL	--	●	○	--	--
Ligno	--	●	●	--	--
Anodized Look	●	●	●	○	--
ALUCOBOND® design	○	●	●	--	--
Anodized	●	●	○	--	--
Mill Finished	●	●	●	--	--

○ - Por pedido

Gama do produto ALUCOBOND® A2

Espessuras: 3 / 4 mm (6 mm por pedido)

Largura [mm]	1 000	1 250	1 500	1 575	1 650
Comprimento [mm]	2 000 – 6 800 mm				
Solid Colours	--	●	●	--	○
Metallic Colours	--	●	●	--	○
Spectra & sparkling	--	●	●	--	--
naturAL	--	○	○	--	--
Ligno	--	●	●	--	--
Anodized Look	--	●	●	--	--
Mill finished	--	●	●	--	--

○ - Por pedido

Sistemas de Fixação

ALUCOBOND®

Sistemas de fixação

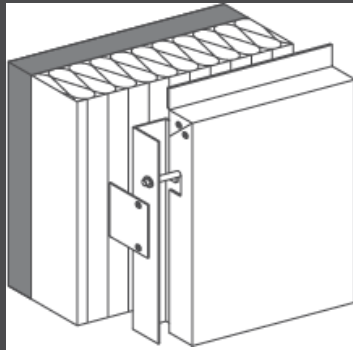

**Cassete suspensa
(Tray Panels)**

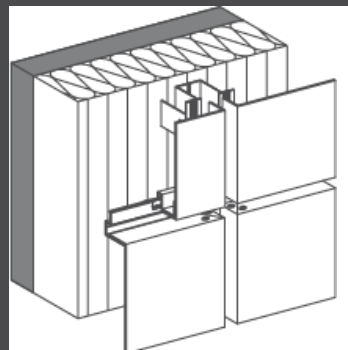

Cassete SZ20

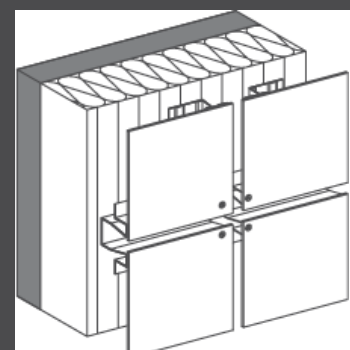

Rebitado

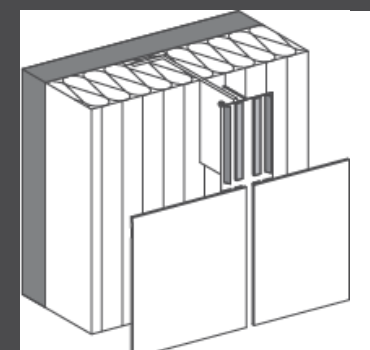

Colagem

Sistemas de fixação

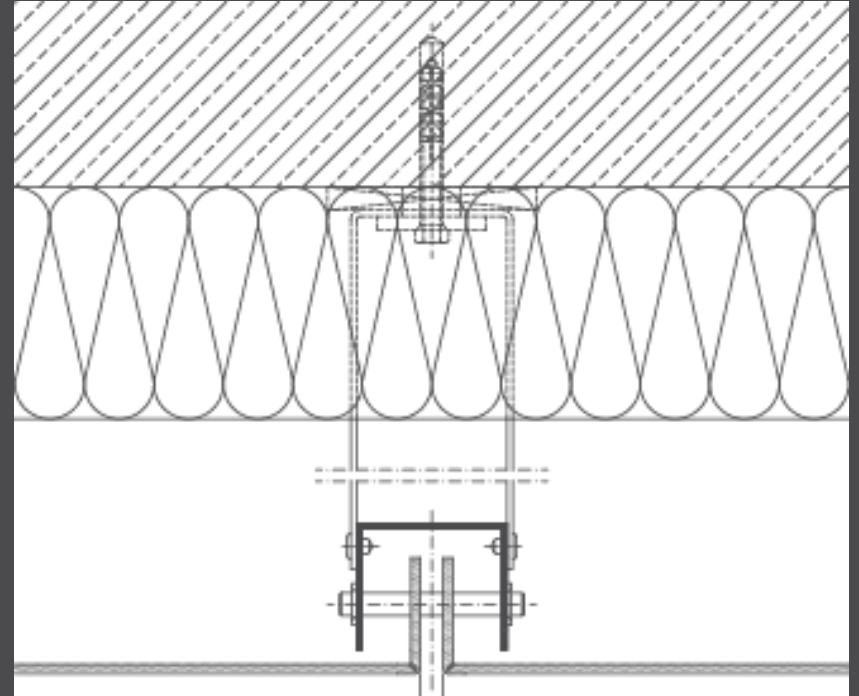
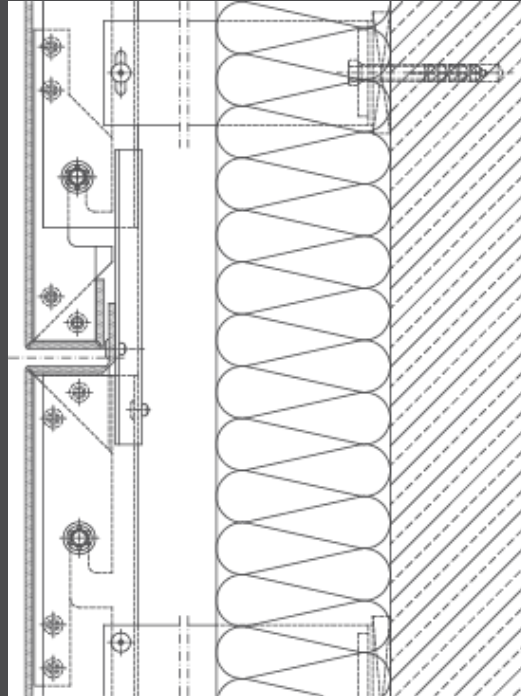
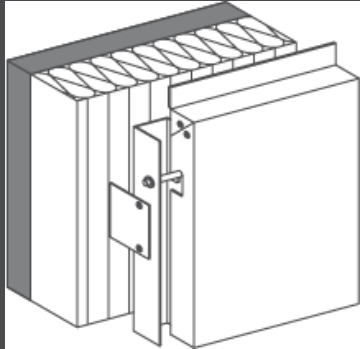

Cassete Suspensa
estruturação de fachada vertical

Concert & Congress HALL | Uppsala, Suécia



Henning Larsen Architects, Denmark | Cassete suspensa

Edifício LIVE'IN Glicínias | Aveiro, Portugal



Edifício Administrativo empresa Poço | Leiria, Portugal



Centro de Comando Operacional REFER | Porto, Portugal



Gare Marítima do Funchal | Madeira, Portugal



Gare Marítima do Funchal | Madeira, Portugal



Sistemas de fixação

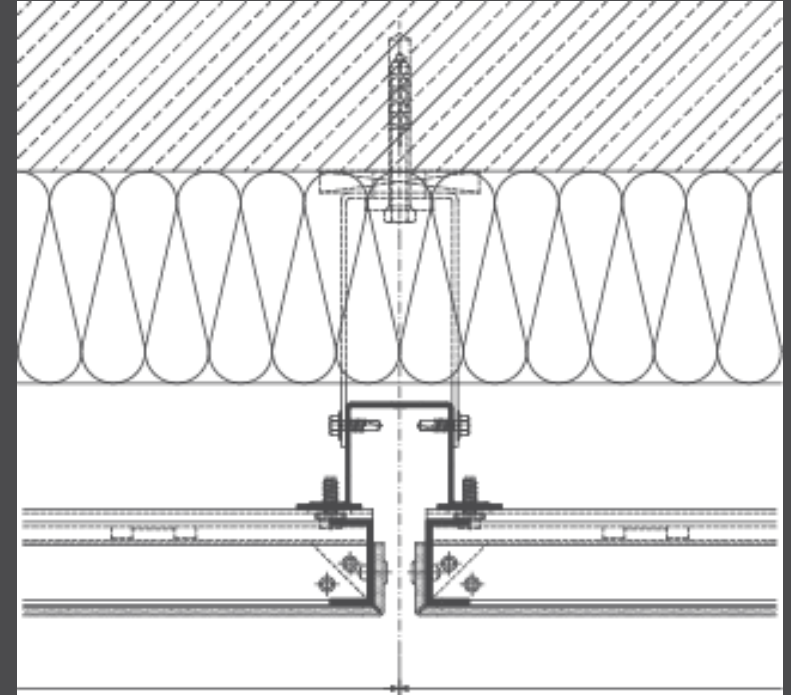
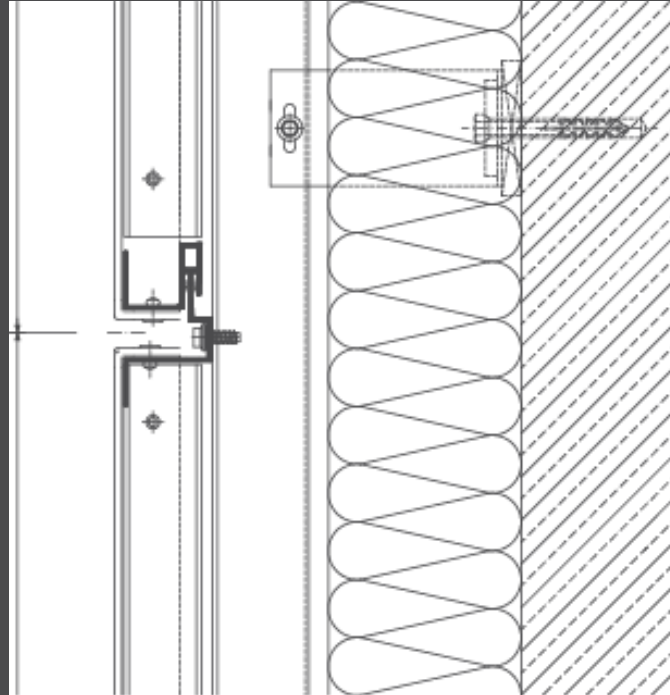
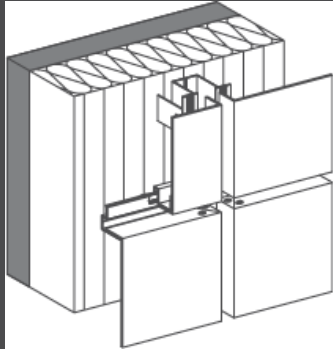

Cassete SZ20
estruturação de fachada horizontal

Marc Cain headquarters | Bodelshausen, Alemanha



Cassette SZ20

Edifício Cultural | Engen, Alemanha



Cassette SZ20

Edifício Cultural | Aalborg, Dinamarca



Cassette SZ20

Sistemas de fixação

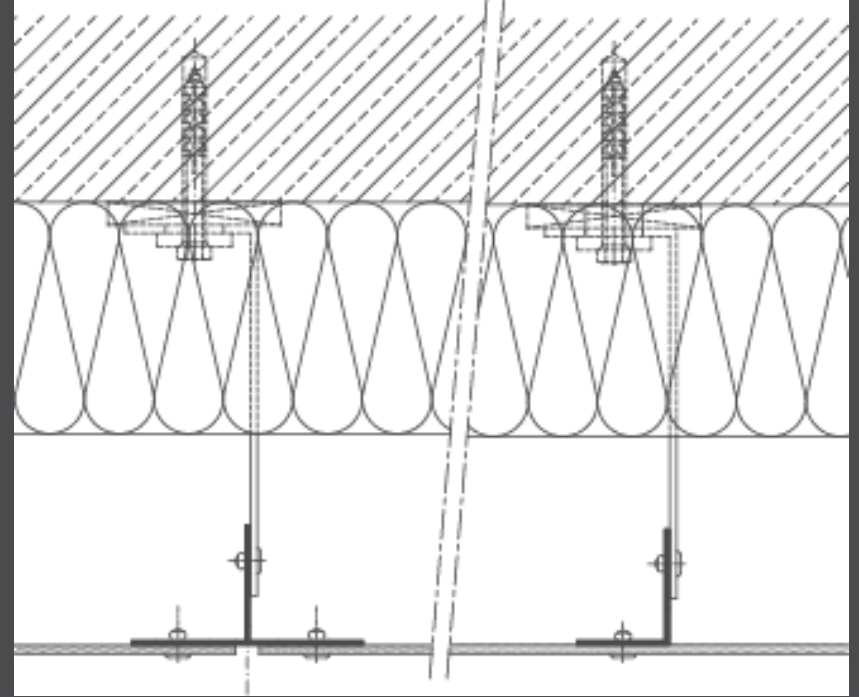
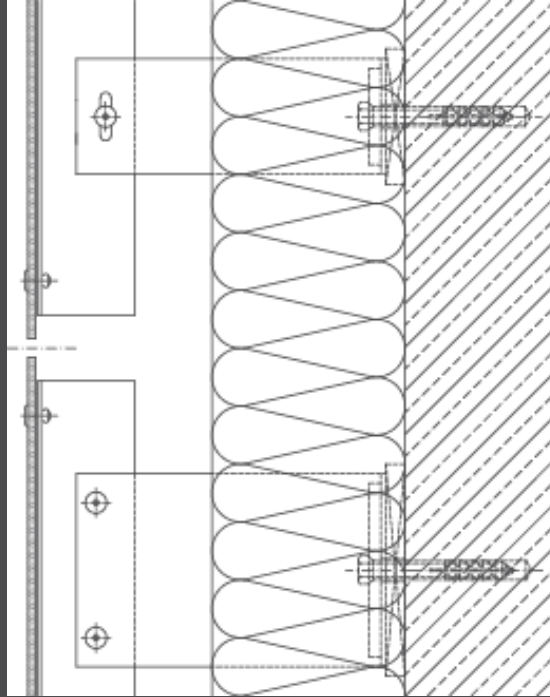
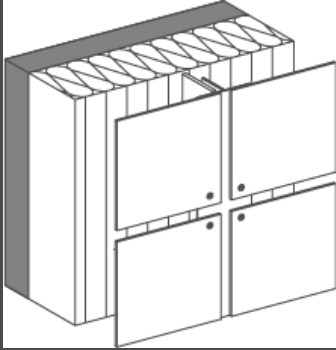

Rebite

Cruise Centre Altona | Hamburg, Alemanha

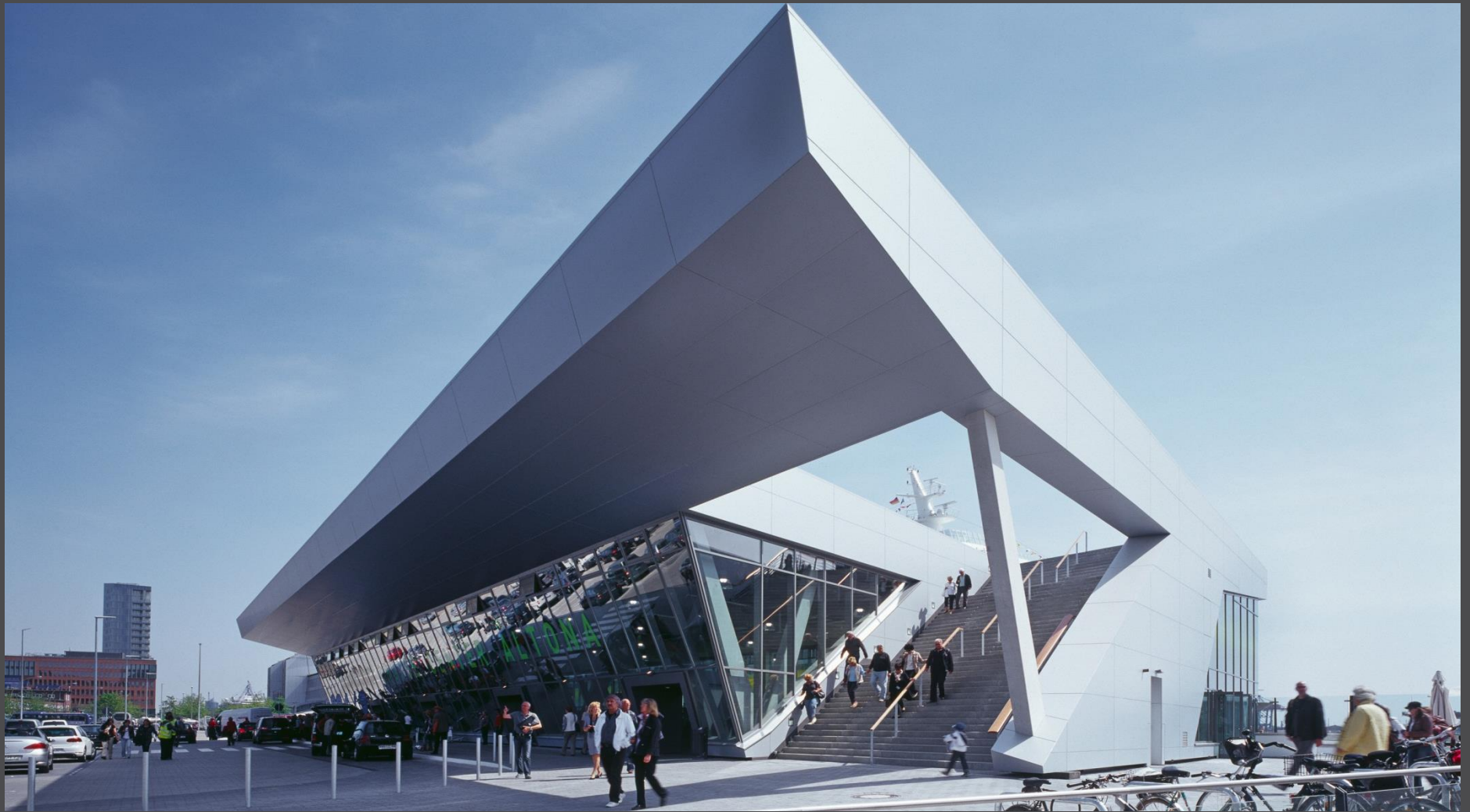

Fixação por rebite

Edifício Cultural | Fremantle, Austrália



Fixação por rebite

Sistemas de fixação

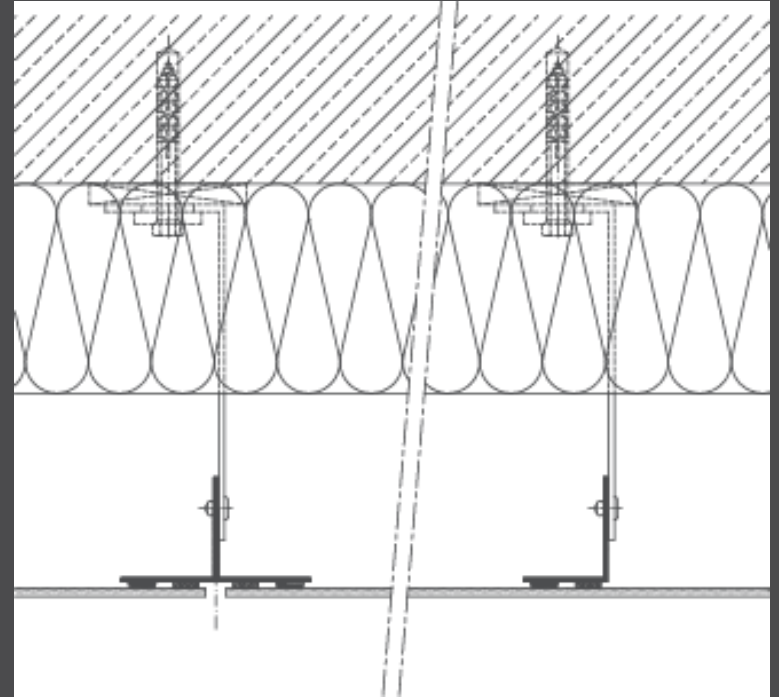
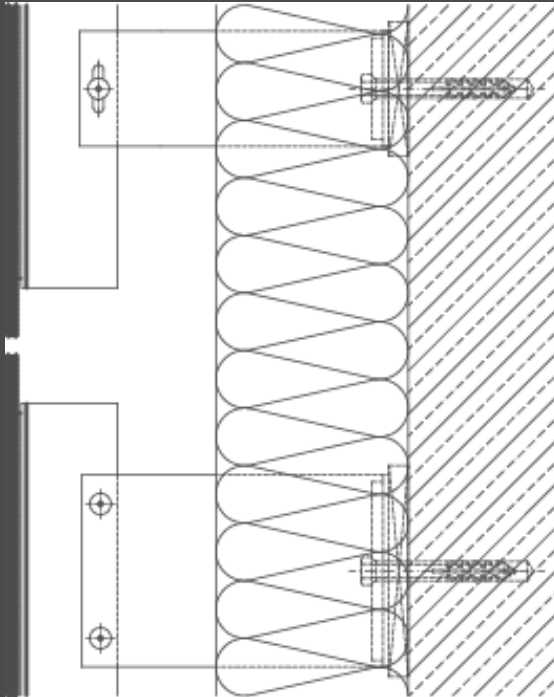
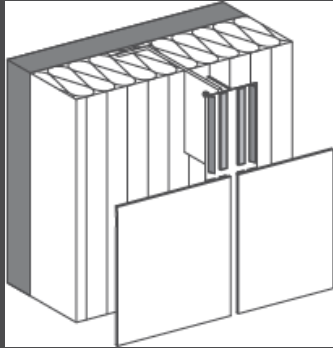

Colagem

IMF Tertia GmbH | Lannach, Austria



Sistema por colagem

Ensino e investigação | Kaufbeuren, Alemanha



Sistema por colagem

Escritórios | Brisbane, Austrália



Sistema por colagem

Reabilitação

ALUCOBOND®

Reabilitação



Antes

Depois



Wundtstrasse Dresden Alemanha

Reabilitação



Höxterstrasse – Hagen Alemanha

Reabilitação

Antes



Depois



Scharnhorst Dortmund - Alemanha

Create the difference.

ALUCOBOND